



## 5451 Plug-in Rate-of-Rise Thermal Detector with Fixed Temperature Alarm

---

### Specifications

Diameter:	4.1 inches (104 mm)
Height:	2.1 inches (53 mm)
Weight:	5 ounces (150 g)
Installation Temperatures:	32° to 100°F (0° to 38°C)
Operating Humidity Range:	10% to 93% Relative Humidity
Latching Alarm:	Reset by momentary power interruption
Sensitivity	135°F (57°C) Fixed or 15°F/min rate-of-rise
Operating Voltage:	15-35 VDC
Standby Current:	100 µA

---

### Before Installing

This detector must be installed in compliance with the control panel installation manual and meet the requirements of the authority having jurisdiction. In addition, the National Fire Protection Association has published codes, standards, and recommended practices for the installation and use of detectors, NFPA 72.

Therefore, the installer must be familiar with these requirements, with local codes, and any special requirements of the authority having jurisdiction.

**NOTICE:** This manual should be left with the owner/user of this equipment.

**IMPORTANT:** This detector must be tested and maintained regularly following NFPA 72 requirements. The detector should be cleaned at least once a year.

### General Description

Model 5451 is a rate-of-rise with fixed temperature alarm thermal detector utilizing a state-of-the-art dual thermistor sensing circuit. These detectors are designed to provide open area protection with 50-foot spacing capability, and are to be used with compatible control panels only.

Two LEDs on each detector light to provide 360° visibility of the detector indication. Remote LED annunciator capability is provided as standard, and the RA400Z remote LED annunciator is available as an optional accessory.

### Base Selection and Wiring Guide

Refer to the installation instructions for the plug-in detector bases for base selection and wiring instructions. System Sensor has available a variety of detector bases for these heat detectors, including 2-wire applications with and without relays and/or current limiting resistors for use with control panels that require one. This detector is only to be used with 400 and 400B series bases.

Install the System Sensor plug-in base to be used with the detector following the instructions in the base manual.

## Installation

**NOTE:** All wiring must conform to applicable installation codes and regulations.

**NOTE:** Verify that all detector bases are installed, that the initiating-device circuits have been tested, and that the wiring is correct. (Refer to detector base manual for testing procedure.)



---

Disconnect the power from initiating-device circuits before installing detectors.

---

1. Install Detectors:
  - a. Insert the detector into the detector base.
  - b. Turn the detector clockwise until the detector drops into place.
  - c. Continue turning detector clockwise to lock it in place.
2. After all detectors have been installed, apply power to the control unit.
3. Test the detector using the magnet as described under TESTING.
4. Reset the detector at the system control panel.
5. Notify the proper authorities that the system is in operation.

## Tamper Resistance

The detector bases include a feature that, when activated, prevents removal of the detector without the use of a tool. Refer to the installation instruction manual of the detector base to make use of this capability.

## Testing

Before testing, notify the proper authorities that the heat detector system is undergoing maintenance, and therefore the system will temporarily be out of service. Disable the zone or system undergoing maintenance to prevent unwanted alarms.

Detectors must be tested after installation and periodic maintenance. The 5451 may be tested as follows:

### A. Test Magnet (System Sensor Model No. M02-04)

1. Position the magnet against the cover opposite the test module socket. (See Figure 1.)
2. The LEDs on the detector should light within 10 seconds. If the LEDs fail to light, check the power to the detector and the wiring in the detector base.
3. Reset the detector at the system control panel.

**Figure 1. Bottom and Side Views Showing Position of Test Magnet:**

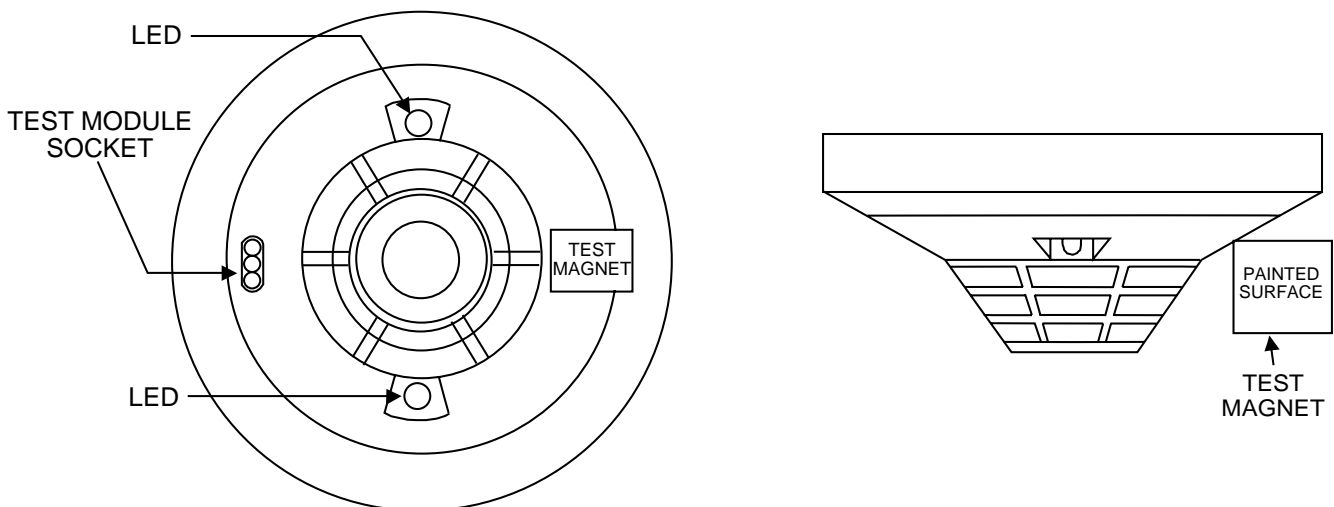

B. Test Module (System Sensor Model No. MOD400 or MOD400R)

The MOD400 or MOD400R is used with a DMM or volt meter to check the detector sensitivity as described in the module's manual.

C. Direct Heat Method (Hair dryer of 1000 - 1500 watts)

From the side of the detector, direct the heat toward the sensor. Hold the heat source about 15 cm away to prevent damage to the cover during testing.

**NOTE:** If a detector goes into alarm, it will reset only if the detector has cooled and if its power is momentarily interrupted. Check the control panel being used to determine whether the RESET switch (or some other auxiliary device or control) momentarily cuts off power to the detector loop.

Detectors that fail these tests should be cleaned as described under MAINTENANCE and retested. If the detectors still fail these tests they should be returned for repair.

**Maintenance**

The 5451 detector has been designed to be as maintenance-free as possible. Normal air-borne dust, however, can accumulate on the detector's sensing elements and cause them to become less sensitive. All detectors should be tested and cleaned at least once a year, and those in dustier areas should be tested and cleaned more often. Detectors must also be cleaned and tested immediately after a fire.

Before cleaning, notify the proper authorities that the system is undergoing maintenance and therefore the system will temporarily be out of service. Disable the loop or system undergoing maintenance to prevent unwanted alarms.

1. Remove detector from mounting base.
2. Use a vacuum cleaner to remove dust from the sensing chamber.
3. Reinstall the detector.
4. Test detector as described under TESTING.

**Please refer to insert for the Limitations of Fire Alarm Systems**

**Three-Year Limited Warranty**

System Sensor warrants its enclosed heat detector to be free from defects in materials and workmanship under normal use and service for a period of three years from date of manufacture. System Sensor makes no other express warranty for this heat detector. No agent, representative, dealer, or employee of the Company has the authority to increase or alter the obligations or limitations of this Warranty. The Company's obligation of this Warranty shall be limited to the repair or replacement of any part of the heat detector which is found to be defective in materials or workmanship under normal use and service during the three year period commencing with the date of manufacture. After phoning System Sensor's toll free number 800-SENSOR2 (736-7672) for a Return Authorization number, send defective units postage prepaid to: System Sensor, Repair

Department, RA # \_\_\_\_\_, 3825 Ohio Avenue, St. Charles, IL 60174. Please include a note describing the malfunction and suspected cause of failure. The Company shall not be obligated to repair or replace units which are found to be defective because of damage, unreasonable use, modifications, or alterations occurring after the date of manufacture. In no case shall the Company be liable for any consequential or incidental damages for breach of this or any other Warranty, expressed or implied whatsoever, even if the loss or damage is caused by the Company's negligence or fault. Some states do not allow the exclusion or limitation of incidental or consequential damages, so the above limitation or exclusion may not apply to you. This Warranty gives you specific legal rights, and you may also have other rights which vary from state to state.