

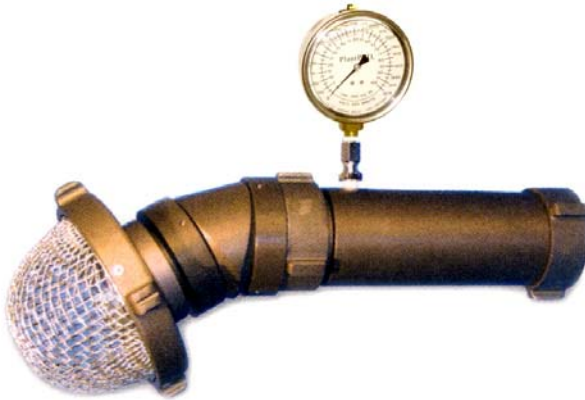

Hydrant Flow Test Kit

2½" NST NH Hydrant Diffuser with Debris Screen

Hydrant Flow Test Kits include a 2-1/2" barrel with Pitot tube properly positioned in the waterway, 4" Dual Read Psi-GPM gauge and Water Diffuser Assembly. This kit allows you to swivel and aim flow with it's 30° Swivel.



- A 4" dial liquid filled, 0-100 PSI -1675 GPM Dual Read Gauge is standard.
- Gauge face is marked in large 2.5 PSI increments and has a ±1% full scale accuracy
- Gauge swivels 360° for easy reading and is removable for remote location mounting.
- Hydrant debris, etc. are retained in the Diffuser Assembly.
- The 2-1/2" barrel easily measures flow & is adaptable with hose for flushing.

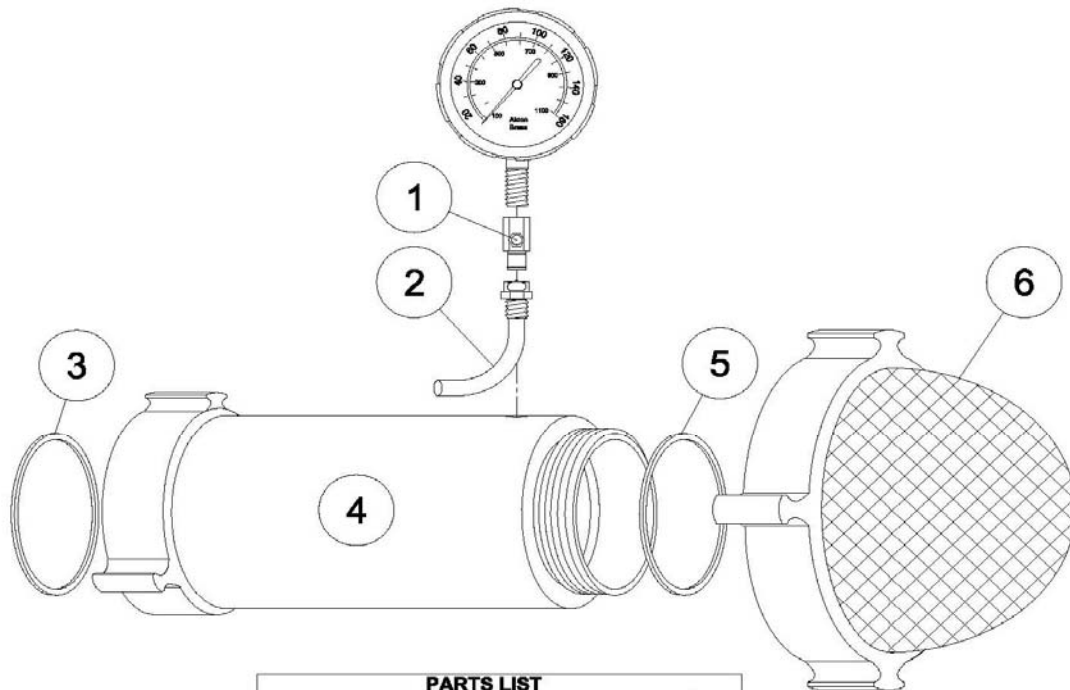

PARTS LIST			
ITEM NO.	PART NO.	DESCRIPTION	QTY.
1	FK-109	BLEEDER ADAPTER ASSY.	1
2	FK-500	PITOT TUBE/BLEEDER ASSY	1
3	FK-800	SWIVEL GASKET	1
4	FK-400	2.5" BARREL	1
5	FK-801	TIP GASKET	1
6	HKD-25	BASKET DIFFUSER	1