

**DATA SHEET  
#SPS350**

**MODEL HR-2  
RESIDENTIAL PENDENT  
SIN: AS3051**

**Model**

- "Automatic" Residential Pendent Glass Bulb Sprinklers, Model HR-2 - 3/8" Orifice x 1/2" NPT - Pendent

**K Factor**

- 3.0 (4.3)

**Sprinkler Identification Number (SIN)**

- AS3051

**Approvals**

- UL Listed, ULC Listed

**To Specify**

- Furnish and install "Automatic" Sprinkler Brand Model HR-2 Residential Pendent Glass Bulb Sprinkler. Style, NPT, orifice, K-Factor, finish, and temperature rating as required.

**Temperature Ratings**

- 155°F (68°C)

**Finishes**

- Plain Brass
- Chrome Plated
- White
- Bright Brass

**Note:**

See back of page for ordering information and installation data.

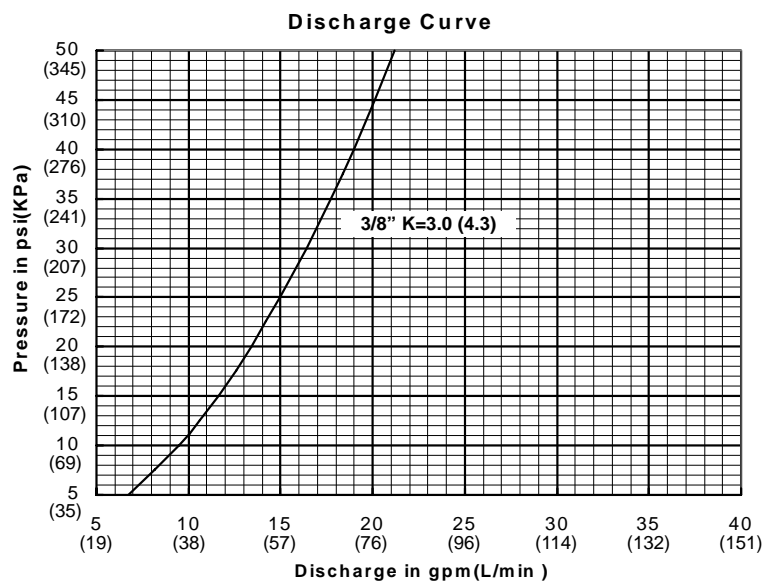
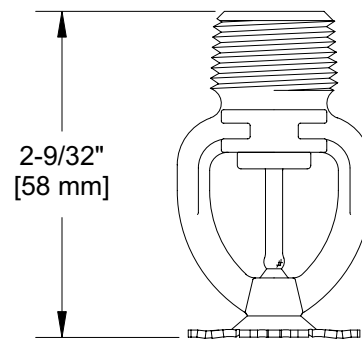

# QUICK RESPONSE SUBMITTAL SHEET

## ***Design and Installation***

The design and installation of residential sprinkler systems shall comply with the applicable standards of **NFPA 13**, "Installation of Sprinkler Systems"; **NFPA 13D**, "Installation of Sprinkler Systems in One- and Two-Family Dwellings and Mobile Homes"; **NFPA 13R**, "Installation of Sprinkler Systems in Residential Occupancies up to Four Stories in Height" and the Authority Having Jurisdiction.

## ***Ordering Information***

- "Automatic" Model HR-2 - Residential - 3/8" Orifice x 1/2" NPT - Pendent

Type	Temperature Rating	Maximum Ambient Temperature	K Factor	Finish	Stock Code No.	Submittal (Check One)
Model HR-2	155°F (68°C) (Red Bulb)	100°F (38°C)	3.0 (4.3)	Brass	8887320	
				Chrome	8887321	
				White	8887327	
				Bright Brass	8887328	

## ***Installation Data***

Maximum Coverage Area (ft)		Minimum Flow Rate (gpm/Sprinkler)		Minimum Pressure (psi)	
Width	Length	Single Sprinkler	Multiple Sprinkler	Single Sprinkler	Multiple Sprinkler
12	12	9.0	9.0	9.0	9.0
14	14	10.0	10.0	11.1	11.1
16	16	12.0	11.5	16.0	14.7
1	18	13.0	12.5	18.8	17.4
20	20	16.0	14.0	28.4	21.8

This information is only a general guideline. The company reserves the right to change any portion of this information without notice. Terms and conditions of sale apply and are available on request.

07/01 Printed in USA SPS350.QXD

**"Automatic" Sprinkler Fire Protection Equipment**  
Distributors: NNI INC. Tel: 877-NNI-FIRE, 305-756-1102, Fax: 305-757-1902