

521 BRASS SWING CHECK VALVE

- ❖ Swing Type
- ❖ Cast Brass
- ❖ Screwed Cap
- ❖ Insert Threaded or Solder Ends
- ❖ Integral Seats

200 PSI NON SHOCK WOG 125 PSI SWP

Applications: Commercial, Light Industrial for Water, Oil, Gas or Steam

Threaded Ends Conform to ANSI Standards B2.1
 Solder Ends Conform to ANSI Standard B16.18
 Valves are Tested in Accordance with MSS-SP-82

521N Also Available
 Same As 521 With Neoprene Disc



DIMENSIONS

SIZE (inches)	H	L	L1	Weights (lbs)		
				521T	521C	521N
3/8	1.50	-	-	.38	-	.42
1/2	1.50	2.07	2.56	.40	.36	.40
3/4	1.60	2.34	3.15	.52	.52	.54
1	1.69	2.58	3.82	.68	.74	.72
1-1/4	1.85	3.15	4.29	1.24	1.24	1.32
1-1/2	2.17	3.49	4.89	1.72	1.58	1.74
2	2.72	4.20	5.51	2.60	2.62	2.70
2-1/2	2.96	5.16	-	4.40	-	4.56
3	3.82	5.79	-	6.62	7.08	6.90
4	3.94	6.86	-	10.18	-	10.54

MATERIAL SPECIFICATIONS

NO.	PART	MATERIAL	ASTM SPEC
1	Body	Brass	B584 C857
2	Disc	Brass	B124 C377
3	Seat	BUNA	Commercial
4	Nut	Brass	B16 C360
5	Pin	Brass	B16 C360
6	Plug	Brass	B16 C360
7	Cap	Brass	B584 C857

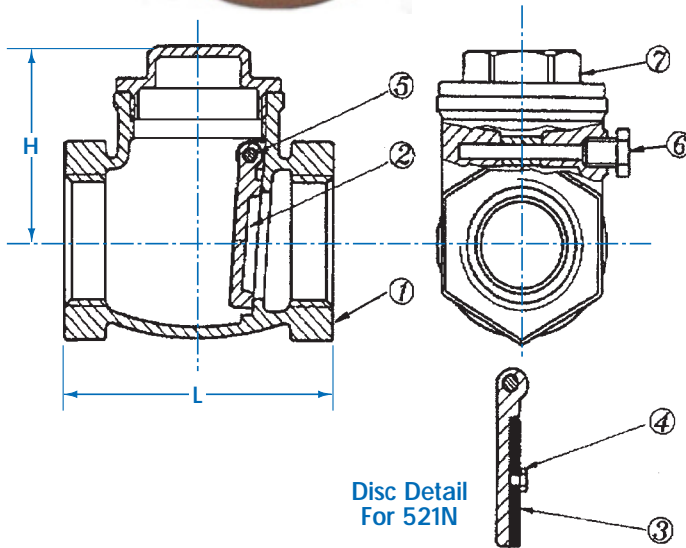

Disc Detail
For 521N

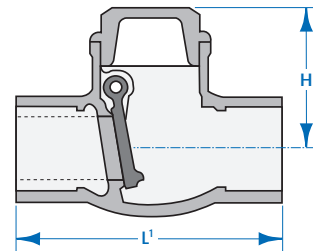

IPS

C x C