

530 BRONZE SWING CHECK VALVE

❖ horizontal pattern ❖ bronze disc ❖ threaded cap

300 PSI NON-SHOCK WOG 150 PSI SWP

Applications: Commercial, Light Industrial for Water, Oil, Gas and Steam

Threaded Ends Conform to ANSI Standards B2.1
Valves are Tested in Accordance with MSS-SP-82



DIMENSIONS

SIZE (inch)	d	L	H	Wts (lbs)
3/8	.49	2.09	1.46	.46
1/2	.51	2.09	1.46	.52
3/4	.75	2.36	1.61	.64
1	.98	2.76	1.85	.90
1-1/4	1.22	3.19	2.24	1.46
1-1/2	1.46	3.53	2.44	1.88
2	1.93	4.25	2.72	2.78
2-1/2	2.21	5.39	3.38	5.34
3	2.68	5.91	3.62	7.26
4	3.54	7.09	4.33	12.50

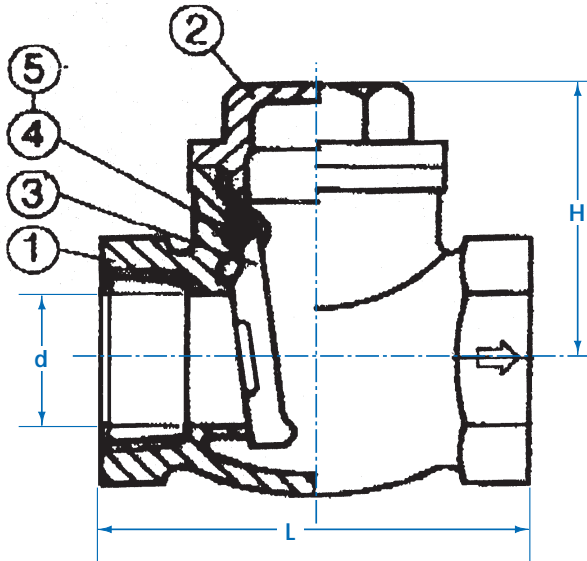

MATERIAL SPECIFICATIONS

NO.	PART	MATERIAL	ASTM SPEC
1	Body	Bronze	B-62
2	Cover	Bronze	B-62
3	Disc	Bronze	B-62
4	Pin	Brass Rod	B-16
5	Bolt	Brass Rod	B-16