

100W CAST IRON GATE VALVE

- ❖ Resilient Wedge
- ❖ Flanged Ends
- ❖ Bolted Bonnet
- ❖ Non Rising Stem
- ❖ Bronze Stem
- ❖ Class 125 Flanges

200 PSI NON-SHOCK WOG MAXIMUM TEMPERATURE 140°F

Applications: Irrigation, Potable Water, Turf, Golf Course,
Water Distribution Service & Feed Lines, Sewage Disposal

Conforms with AWWA C509 Specifications

Flanges Conform with ANSI B16.1

ISO 9002

DIMENSIONS & WEIGHTS

SIZE d ₀ INCHES	L	D ₀	C ₀	h ₀	n	T	W ₀	H2	S	APPROX. WT. LBS.
2	7.0	6.0	4.75	.75	4.0	.63	7.06	14.56	1.09	47
2.5	7.5	7.0	5.50	.75	4.0	.69	7.06	15.50	1.09	50
3	8.0	7.5	6.00	.75	4.0	.75	7.81	17.50	1.25	60
4	9.0	9.0	7.50	.88	8.0	.94	9.88	20.00	1.25	85
6	10.5	11.0	9.50	.88	8.0	1.00	11.80	25.25	1.41	146
8	11.5	13.5	11.75	.88	8.0	1.13	11.80	30.06	1.56	244
10	13.0	16.0	14.25	1.00	12.0	1.19	15.63	35.38	1.56	389
12	14.0	19.0	17.00	1.00	12.0	1.25	15.63	40.38	1.56	532
14	15.0	21.0	18.75	1.13	12.0	1.38	15.75	49.00	1.63	807
16	16.0	23.5	21.25	1.13	16.0	1.44	17.69	55.25	1.63	1160

MATERIAL SPECIFICATIONS

NO.	PART	MATERIAL	ASTM DESIGNATION
1	Body	Cast Iron	A 126 CLASS B
2	Bonnet	Cast Iron	A 126 Class B
3	Stuffing Box	Cast Iron	A 126 Class B
4	Disc	Cast Iron & Rubber (D2000)	A 126 Class B
5	Operating Nut	Cast Iron	A 126 Class B
6	Hand Wheel	Cast Iron	A 126 Class B
7	Stem	Bronze	B 21
8	Stem Nut	Bronze	B 62
9	Thrust Washer	Brass	B 36
10	Bonnet Bolt & Nut	Zinc Coated Steel	A 307 Grade B
11	Stuffing Box Bolt	Zinc Coated Steel	A 307 Grade B
12	Hand Wheel Washer	Zinc Coated Steel	A 284
13	Top Nut	Zinc Coated Steel	A 307 Grade B
14	Bonnet Gasket	Rubber	D 2000 AA 6014
15	O Ring A	Rubber	D 2000 AA 6014
16	O Ring B	Rubber	D 2000 AA 6014
17	Wiper Ring	Rubber	D 2000 AA 6014
18	Gland	Rubber	D 2000 AA 6014
19	O Ring C	Rubber	D 2000 AA 6014
20	Stuffing Box Nut	Brass	B 36

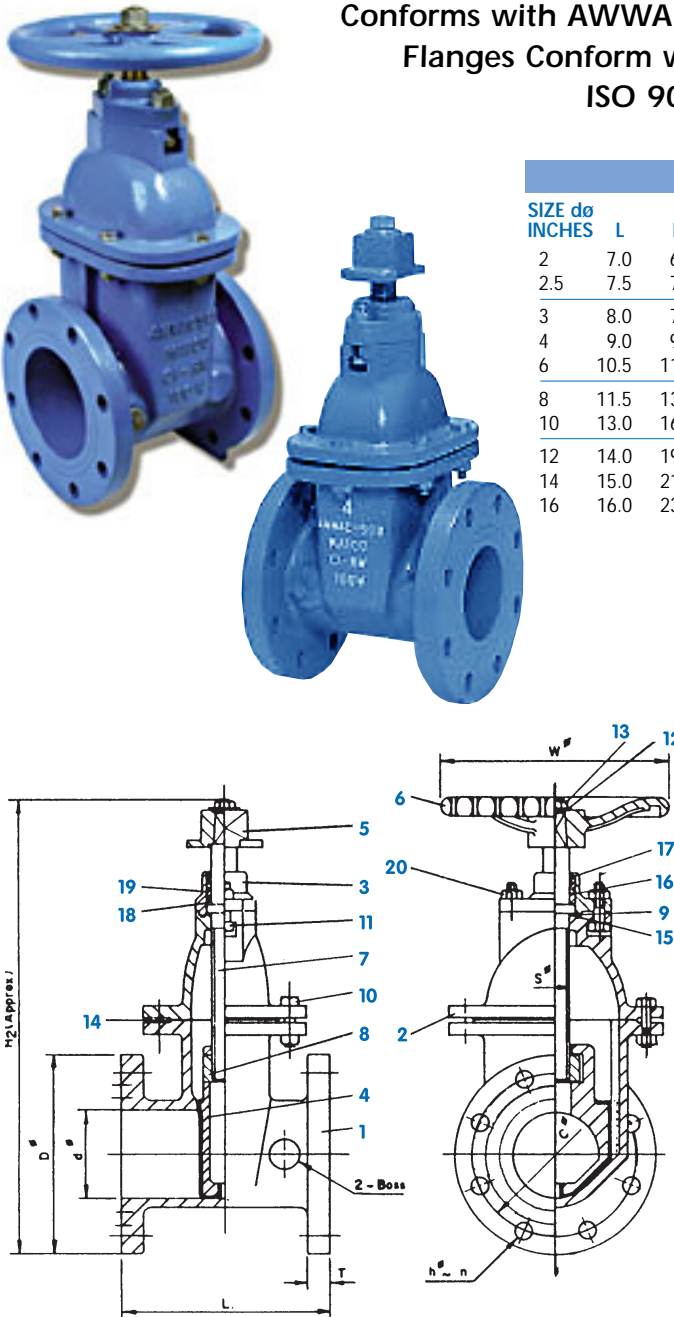

Product Spec Sheet

