

10RW CAST IRON GATE VALVE

- ❖ Flanged Ends
- ❖ Resilient Wedge
- ❖ Epoxy Coating - Internal & External
- ❖ Stainless Steel Stem

200 PSI NON-SHOCK WOG MAXIMUM TEMPERATURE 140°F

Applications: Irrigation, Potable Water, Turf, Golf Course,
Water Distribution Service & Feed Lines, Sewage Disposal

Tested to AWWA C509 Section 5

ASTM A126 Class B

Flanged Ends Conform with ANSI B16.1

ISO 9002

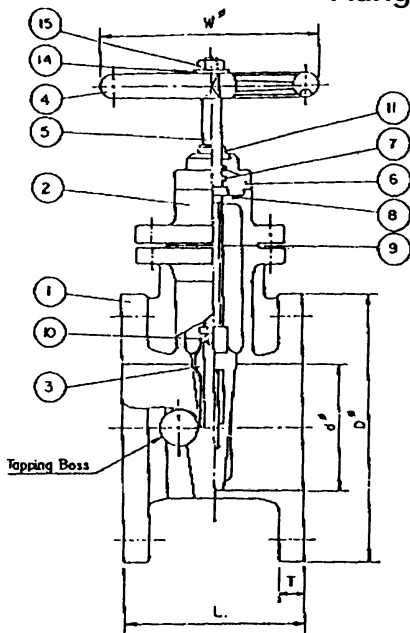

DIMENSIONS & WEIGHTS

SIZE dø inch	L	Dø	Cø	hø	n	T	Wø	H	H1	S	WT. LBS.
2	7.00	6.00	4.75	.75	4.00	.63	7.06	8.50	3.00	.63	25
2.5	7.50	7.00	5.50	.75	4.00	.69	7.06	9.38	3.50	.63	30
3	8.00	7.50	6.00	.75	4.00	.75	7.88	10.25	3.75	.69	42
4	9.00	9.00	7.50	.75	8.00	.94	8.81	12.19	4.50	.81	64
5	10.00	10.00	8.50	.88	8.00	.94	9.88	14.37	5.00	.88	96
6	10.50	11.00	9.50	.88	8.00	1.00	11.00	16.00	5.50	.94	108
8	11.50	13.50	11.75	.88	8.00	1.13	11.00	19.93	6.75	1.00	191
10	13.00	16.00	14.25	1.00	12.00	1.19	12.44	23.80	8.00	1.25	286
12	14.00	19.00	17.00	1.00	12.00	1.25	14.00	26.75	9.50	1.25	392

MATERIAL SPECIFICATIONS

NO.	PART	MATERIAL	ASTM DESIGNATION
1	Body	Cast Iron	A 126 Class B
2	Bonnet	Cast Iron	A 126 Class B
3	Disc	Cast Iron B Rubber (Buna-N)	A 126 Class B
4	Hand Wheel	Cast Iron	A 126 Class B
5	Stem	Stainless Steel	A 276 Type 304
6	Stuffing Box	Cast Iron	A 126 Class B
7	O-Ring A	Rubber	D 2000 AA 6014
8	O-Ring B	Rubber	D 2000 AA 6014
9	Bonnet Gasket	Rubber	D 2000 AA 6014
10	Stem Nut	Stainless Steel	A 276 Type 304
11	Wiper Ring	Rubber	D 2000 AA 6014
12	Bonnet Bolt & Nut	Steel	A 307 Grade B
13	Stud & Nut	Steel	A 307 Grade B
14	Hand Wheel Washer	Steel	A 307 Grade B
15	Top Nut	Steel	A 307 Grade B
16	Operating Nut	Cast Iron	A 126 Class B

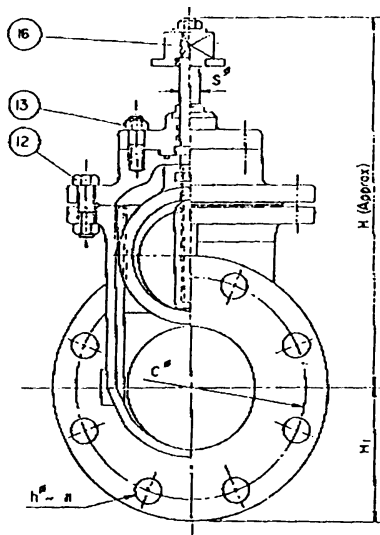

Product SpecSheet