

200W CAST IRON GATE VALVE

- ❖ Resilient Wedge ❖ Flanged Ends ❖ Non Rising Stem
 - ❖ Bolted Bonnet ❖ Epoxy Coated ❖ Stainless Steel Stem
- 200 PSI NON-SHOCK WOG MAXIMUM TEMPERATURE 140°F**

Applications: Irrigation, Potable Water, Turf, Golf Course,
Water Distribution Service & Feed Lines, Sewage Disposal

Conforms with AWWA C509
Flanges Conform With ANSI B16.1

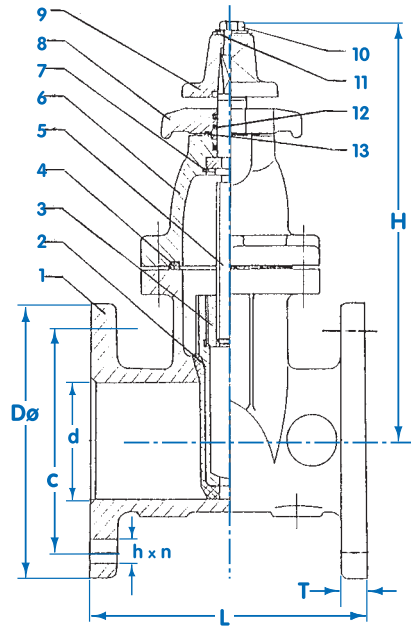

DIMENSIONS & WEIGHTS

SIZE dø (inch)	L	Dø	Cø	hø	n	T	Wø	H	Sø	APROX. WT. LBS.
2"	7.0	6.0	4.75	.75	4	.63	7.87	9.84	.94	31
2.5"	7.5	7.0	5.50	.75	4	.71	7.87	11.42	.94	44
3"	8.0	7.5	6.00	.75	4	.75	7.87	12.40	1.10	53
4"	9.0	6.0	7.50	.75	8	.94	9.45	13.98	1.10	86
6"	10.5	11.0	9.50	.88	8	.98	12.60	17.13	1.26	141
8"	11.5	13.5	11.75	.88	8	1.14	14.17	20.87	1.26	231
10"	13.0	16.0	14.25	1.00	12	1.18	15.75	25.39	1.42	359
12"	22.0	19.0	17.00	1.00	12	1.26	15.75	28.35	1.42	513

MATERIAL SPECIFICATIONS

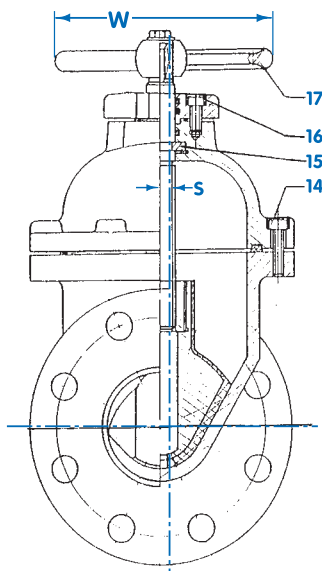

NO.	PART	MATERIAL	ASTM DESIGNATION
1	Body	Cast Iron	A126 CLB
2	Disc	Ductile Iron Buna-N	A395 GR65-45-12 D2000
3	Stem Nut	Bronze	B62
4	Bonnet Gasket	Buna-N	D2000
5	Stem	Stainless Steel	A276 GR304
6	Bonnet	Cast Iron	A126 CLB
7	Clip Ring	Steel	C1065
8	Packing Box	Cast Iron	A126 CLB
9	Operating Nut	Cast Iron	A126 CLB
10	Top Bolt	Steel	A307 GRB
11	Washer	Steel	Commercial
12	O-Ring	Buna-N	D2000
13	Packing Box Gasket	Buna-N	D2000
14	Bonnet Bolt	Steel	A307 GRB
15	Split Ring	Bronze	B62
16	Packing Box Bolt	Steel	A307 GRB
17	Handwheel	Cast Iron	A126 CLB

Product Spec Sheet