

Item Code: 08170  
and 08171



PIPE TOOLS & VISES  
SINCE 1896

Item Code: 08175  
and 08176



# Electric Hydrostatic Test Pumps

## Operator's Manual

EHTP500, EHTP500C,  
EHTP500E, EHTP500CE Models

**SAVE THESE  
INSTRUCTIONS!**

## OPERATING INSTRUCTIONS:

### 1. Prime the Pump.

#### A. From a Pressurized Supply

- Connect a garden hose to the garden hose fitting, making sure the attachment is snug.
- Attach the high pressure hose to the quick connect on the pump.
- Without plugging in or turning on the pump, turn on the supply of water and open the outlet valve.
- Once water begins to flow out of the high-pressure hose and the air is purged out, close the outlet valve.

#### B. From a Non-Pressurized Supply

- Connect a garden hose to the garden hose fitting, making sure the attachment is snug.
- Make sure the hose end is not resting on the bottom or side of the supply container. This will not allow water to flow, causing priming and suction problems with the pump.
- Priming the pump is easier if it is at equal or lower height of the supply container.
- Attach the high pressure hose to the quick connect on the pump.
- Plug in the cord and turn on the pump with the air bleed off (priming valve) open. Water will flow from this valve once the pump begins to prime. **Note:** A hose can be attached to the hose barb and run back to the water supply if desired.
- Close the air bleed-off valve and the pump will quickly prime. Make sure the outlet valve is open.
- Once water begins to flow out of the high-pressure hose and the air is purged out, close the outlet valve and turn off the pump.

#### Priming Tips:

- When priming the pump from a non-pressurized supply, it is recommended to fill the input garden hose before turning on the pump.
- The input fitting for the pump is a standard garden hose connection. When this attachment is made it is important to make sure the garden hose is tightened snugly so that the pump does not suck air through the loose connection. A loose connection will make the pump hard to prime.
- The shorter the garden hose, the easier it is to prime the pump. Long hoses tend to collapse from the suction of the pump when drawing from a non-pressurized system, restricting flow.
- Use a hose that is rigid enough so that it does not collapse, especially when drawing water from a non-pressurized system.

### 2. Connect the High Pressure Hose to the system being checked.

- If the supply water is coming from a pressurized system, it is recommended to fill the system to be tested with water prior to turning on the pump. This can be done simply by opening the Outlet valve on the pump, allowing water to flow through the pump and high-pressure hose into the system being tested. Once the system fills and pressure begins to rise, proceed to the next step.
- Non-pressurized systems should be filled with water prior to attaching the high-pressure hose and turning on the pump, if at all possible. This could speed up the testing process.
- The output fitting at the end of the high-pressure hose is 3/8" NPT. An adaptor may be used to attach this hose to the system that is being pressure tested.

### 3. Plug in the cord and turn on the pump to pressurize the system to the desired test pressure.

- Pressure can be adjusted by turning the pressure adjustment knob on the side of the pump. Turning clockwise will increase the pressure. Turning counter-clockwise will decrease the pressure.

### 4. Once the system reaches the desired pressure, close the outlet valve and turn off the pump.

- Once the pump reaches the set pressure it will continue to run but the water will flow through the Automatic Bypass and recirculate through the pump. It is not recommended to run the pump in bypass mode for more than a couple of minutes. Once the desired pressure is reached, it is unnecessary to continue running the pump. Close the valve, turn off the pump and unplug the cord.
- The pump is equipped with a valve and hose which has a checkvalve to prevent backflow. The checkvalve only works when the the hose is detached from the pump. It is recommended to fill the system being tested through a valve which can be shut for backflow prevention as well.

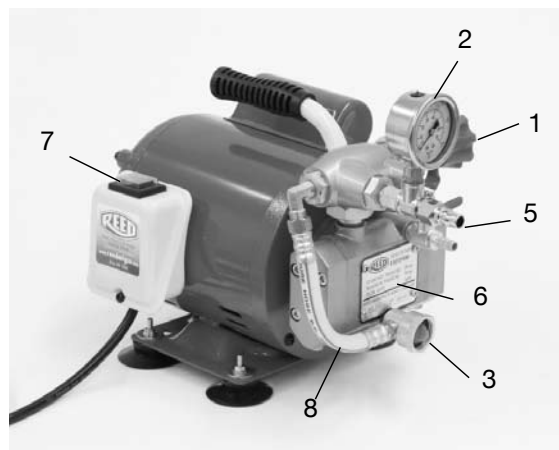
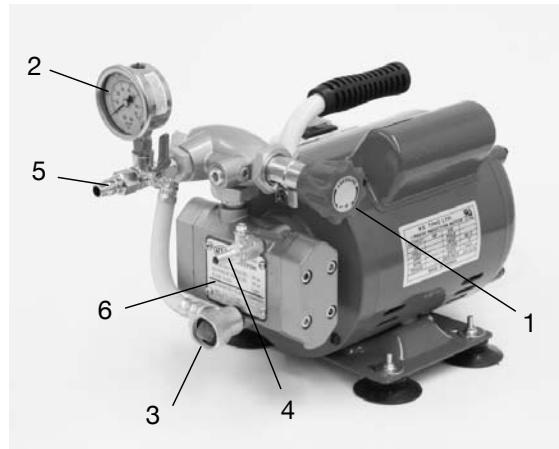

#### Item Description

- Pressure Adjustment Knob
- Pressure Gauge
- Garden Hose Fitting with Screen
- Air Bleed-Off or Priming Valve with Hose Barb
- Outlet Hose Quick-Connection and Outlet Valve
- Front Cover Plate
- On/Off Switch
- Automatic Bypass

## 5. The system is now isolated.

- A. The hose can quick disconnect from the pump and left with the system being tested, if necessary, so that the pump can be used to test another system or stored.

**WARNING: Protect the pump from freezing. Store and transport in a warm place. Or use food grade propylene glycol in the pump to guard against freezing.**

### Safety and Precautionary Instructions:

- Do not use a damaged or worn High Pressure Hose.
- Do not run the pump without a water supply.
- Do not use the pump to fill the system to be tested with water. Fill the system prior to attaching the pump, then attach the pump and pressurize the system.
- Before storing the pump, flush it with clean water and then operate it with a solution of water and food grade propylene glycol to protect and lubricate the internal parts.

### PERIODIC MAINTENANCE:

Every 100 hours, inspect and lubricate the piston and bearing. This is behind the front cover plate of the pump. To access this area, remove the four screws and take off the cover plate. Do not remove the front cover plate while the pump is plugged in or running. Never run a pump without reinstalling the front cover plate. Lubricate with a water resistant, all-purpose lithium grease.

### Motor Specifications

UL Certified  
 3/4 HP 0.55KW Single Phase Induction  
 Voltage: 110/220V  
 Amperage: 12/6.2A  
 Frequency: 60 Hz.

### Pump Specifications

Adjustable Pressure up to a Maximum of 500 psi  
 (34 bar - kg/cm<sup>2</sup>)  
 2 gallons per minute (7 liters/min)  
 Air bleed-off valve (for easier pump priming)

### Parts List

ITEM	DESCRIPTION	ITEM CODE	QTY.
1	BYPASS HOSE	48183	1
2	PRESSURE GAUGE	48185	1
3	HIGH PRESSURE OUTPUT HOSE	08172	1
4	REGULATOR ASSEMBLY	48189	1
5a*	MOTOR ASSEMBLY 110 V.	48187	1
5b*	MOTOR ASSEMBLY 220 V.	48196	1
6	PUMP ASSEMBLY	48188	1
7	SEAL KIT	48181	1
8	PUMP FEET	48190	4
9	CARRYING HANDLE	48191	1
10	ELECTRIC SWITCH / COVER	48193	1
11	CAGE FEET	48186	4

\*Motor Assembly also includes #8, #9 and #10

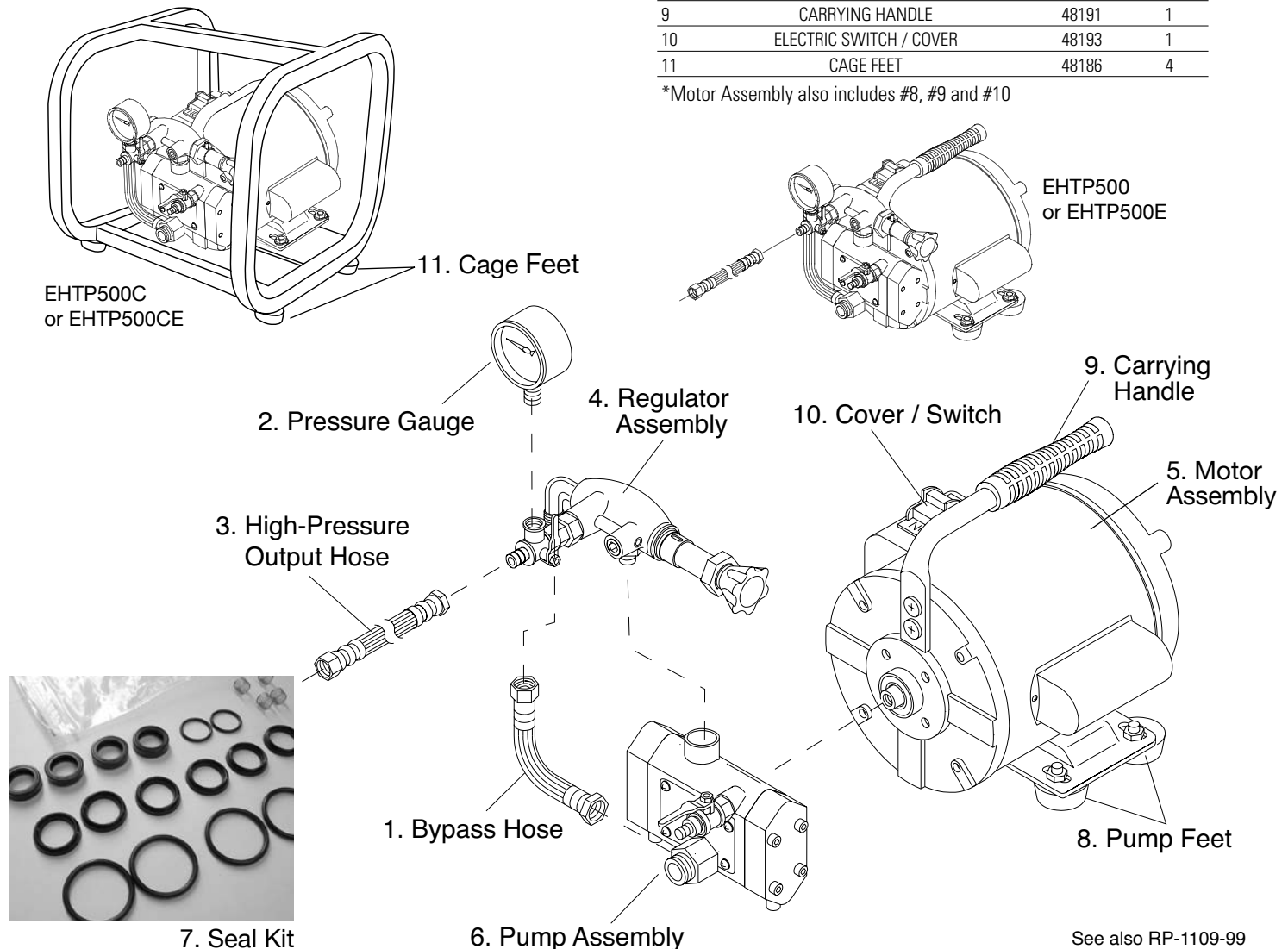

See also RP-1109-99