



Model 453U Check Valve Dual Plate

NNI

453U Grooved End Ductile Iron Body Check Valve Dual Plate

Pressure Temperature Rating
 650 P.S.I. at 150 degrees F
UL Listed. FM Approved.
 Also available in flanged end
 configuration for working pressure of
 250 P.S.I.G.

| | | |
|------------|--------------|------------|
| Body | Ductile Iron | ASTM A536 |
| Plate | Cast Bronze | ASTM B62 |
| Plate Seat | EPDM | Commercial |

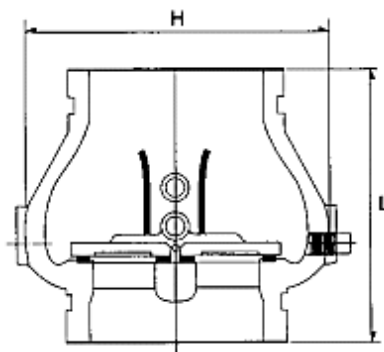

| Price | Size | L | H | WT Lbs |
|-------|---------|----------|----------|--------|
| N/A | 76.2mm | 130.3mm | 139.7mm | 8.8 |
| N/A | 101.6mm | 143mm | 160.27mm | 12.3 |
| N/A | 152.4mm | 177.8mm | 234.95mm | 27.7 |
| N/A | 203.2mm | 209.55mm | 285.75mm | 48.4 |
| N/A | 254mm | 254mm | 339.85mm | 74.8 |
| N/A | 304.8mm | 304.8mm | 412.75mm | 122 |

CHECK VALVES

UL/FM Grooved Check Valves

453UF Flanged End Ductile Iron Body Check Valve Dual Plate

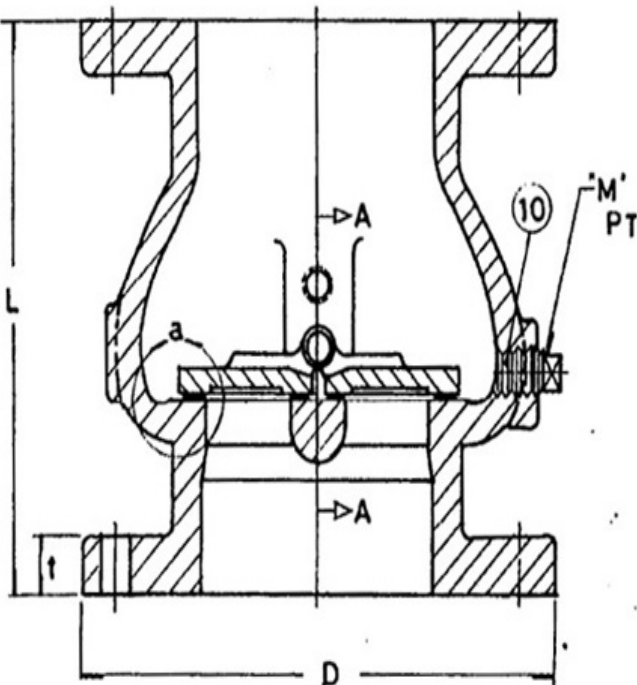
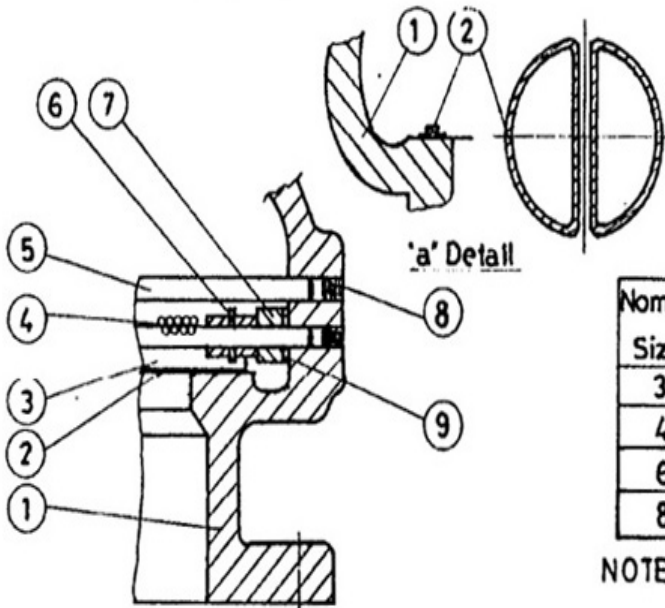

Fig:453UF

MATERIAL LIST

| NO | PART | MATERIAL | ASTM SPEC. |
|----|---------------|-----------------|-------------|
| 1 | Body | Ductile Iron | A 536 |
| 2 | Body Seal | EPDM | |
| 3 | Disc | Cast Bronze | B62(C83600) |
| 4 | Spring | Stainless Steel | AISI 316 |
| 5 | Hinge Pin | Stainless Steel | AISI 316 |
| 6 | Washer | Teflon | |
| 7 | Thrust Washer | Teflon | |
| 8 | Plug | Mild Steel | A 105-80 |
| 9 | Washer | Teflon | |
| 10 | Square Plug | Steel | A 307-B |



SECTION A-A

DIMENSIONS

| Nominal Size | Dimensions | | | | Net. Wt. |
|--------------|--------------------------------|--------------------------------|-------------------------------|-----------------------------|----------|
| | L | D | t | M _{PT} | |
| 3 | 6 ⁵ / ₈ | 7 ¹ / ₂ | ³ / ₄ | ¹ / ₂ | |
| 4 | 7 ¹ / ₂ | 9 | ¹⁵ / ₁₆ | ¹ / ₂ | |
| 6 | 9 | 11 | 1 | ³ / ₄ | |
| 8 | 10 ¹ / ₂ | 13 ¹ / ₂ | 1 ¹ / ₈ | ³ / ₄ | |

NOTE: Available to ANSI or ISO
Flange dimensions See OD-00120