



NON-RISING STEM RESILIENT WEDGE GATE VALVE

STYLE 721-UF Flanged End & 721-UM Mechanical End

FEATURES

- Meets or exceeds all requirements of AWWA C509
- O-Ring Stem Seals
- Painted as standard
- Epoxy coated inside and out to AWWA C550 upon request

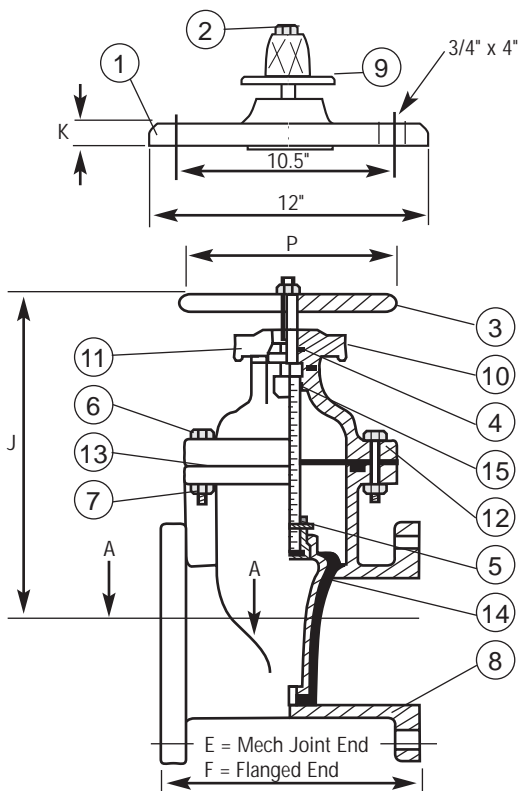

Material List

Item	Description	Material	Specification
1	Ind. Post Flange	Cast Iron	ASTM A126-B
2	Nut	Steel	ASTM A307-B
3	Handwheel	Cast Iron	ASTM A126-B
4	O-Ring	EPDM	Commercial
5	Disc Nut	Cast Bronze	ASTM B-62
6	Bolt	Steel	ASTM A307-B
7	Nut	Steel	ASTM A307-B
8	Body	Cast Iron	ASTM A126-B
9	Operating Nut	Cast Iron	ASTM A126-B
10*	Stem	Brass	ASTM B-16
11	Stuffing Box	Cast Iron	ASTM A126-B
12	Bonnet	Cast Iron	ASTM A126-B
13	Rubber Gasket	EPDM	Commercial
14	Disc	Cast Iron EPDM Coating	ASTM A126-B Commercial
15	O-Ring	EPDM	Commercial

MECHANICAL JOINT END

FLANGED END

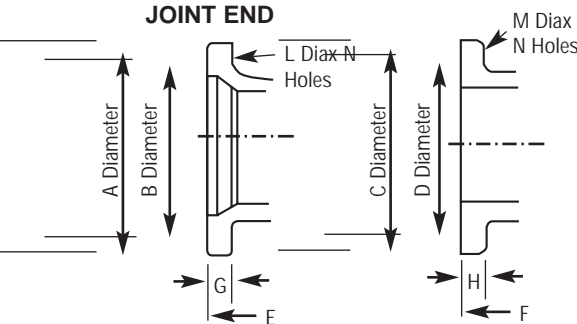

Dimension - Weight

Nom. Size	Dimensions in Inches												Approx. NET Wt. (LBS.)		
	A	B	C	D	E	F	G	H	J	K	LxN	MxN	P	721-UF	721-UM
2-1/2"	-	-	7.0	5.5	-	7.5	-	.69	10.0	-	-	3/4x4	7	42	-
3"	7.69	6.19	7.5	6.0	9.5	8.0	.94	.75	13.9	.65	3/4x4	3/4x4	8	77	90
4"	9.12	7.5	9.0	7.5	11.0	9.0	1.0	.94	14.3	.65	29/32x4	3/4x8	10	104	122
6"	11.12	9.5	11.0	9.5	12.0	10.5	1.06	1.0	18.3	.75	29/32x6	7/8x8	12	182	207
8"	13.37	11.75	13.5	11.8	12.5	11.5	1.12	1.13	21.7	.75	29/32x6	7/8x8	14	246	295
10"	15.62	14.0	16.0	14.3	14.25	13.0	1.19	1.18	25.6	.81	29/32x8	1x12	16	436	498

NOTE

*Stem also available in Bronze or Stainless Steel.

"a step up in value, a step down in cost."™